

TRANSFORMERS AND ELECTRICALS KERALA LIMITEF

(A Joint Venture of Government of Kerala & NTPC Limited)  
 Angamally South P.O., Ernakulam Dist., Kerala, India, Pin: 683573, www.telk.com  
 Phone : 0484 2510251, 2510 ext:330,331,332,334 Fax : 2458995, 2452873 (Angamally)  
 CIN: U31102KL1963SGC002043, Email : contracts@telk.com

ENQUIRY LETTER (OFFICE COPY)

Ref. : PUR/AMM1/25/53

Page : 1  
 Date : 13/01/25

As Per List Attached

PR No.: PP/53/B

Dear Sirs,

We request you to quote for performing the following operations. Please send us your quotation on or before 20/01/25.

S/No	Oprn.Code Item.Code	Description & Specification Description	UOM	Appx. qty Required	Deilvery Before	Delivery Qty.
1	163	TIN PLATING ON TK214201R3B TK 214201R3B CENTRE CONDUCTOR- WITH TIN PLATING ON BOTH AIR END AND OIL END TERMINALS. UNDER COATING 20 MICRONS CU. TIN PLATING 15 MICRONS MIN.AS PER STANDERD IS:2450-1963. TOTAL TIN PLATING AREA ON BOTH SIDES ARE 0.2 SQ.METRE. REFER SPEC NO.2 OF 310346 ALSO	NO	4.000	25/03/25	4.000
	333033109	TK214201R3B CENTRE CONDUCTOR	NO			

1. Prices : Price should be quoted for delivery of materials at our Stores, Angamally / F.O.R. Angamally.
2. Taxes : If any tax has to be paid extra, this and the rate of tax should be specified clearly in your quotation.
3. validity : The quotation should be valid for minimum period of 60 days from the date of opening of tender.
4. Delivery : Delivery is required as above.
5. LD : LD @ 1% per week or part there of subject to a maximum of 10% of order value will be applicable for deliveries beyond the mutually agreed dates
6. Terms and conditions : Please see Annexure.

Note : Quotation should be sent in Sealed Cover

Superscribed Tender No. : AMM1/25/53  
 Due on : 20/01/25  
 Quotation not enclosed in sealed cover and that received after the due date will be rejected.

Yours faithfully,

*Sund*  
 13/1/25  
 ASST. MANAGER (MATERIALS)



Please see annexure enclosed for other terms and conditions

**RATE SCHEDULE FORMAT**

Sl. No.	Description	Total Qty.	Basic Rate per No. (without GST) (Rs)
1.	Rate for Tin Plating on centre conductor, TK214201R3B as per specifications in the enquiry.	4 Nos.	
2.	GST if applicable (%)		
3.	Qty. that can be processed in a batch		..... (Nos.)
4.	Maximum lead time to process and deliver the above batch qty. at TELK Stores		..... days



Authorized Signatory with seal



## GENERAL CONDITIONS OF CONTRACT

### 1. Submission of Tender :

- 1.1 The quotations shall be submitted either in sealed cover or emailed to [telktenders@gmail.com](mailto:telktenders@gmail.com) so as to deliver before the due date. Quotations emailed to any other email addresses are liable to be rejected.
- 1.2 The tender will be considered FIRM for acceptance for a period of 60 days from the date of opening of the tenders. The bidders will not be free to withdraw or modify their tender within this period, except at the risk of forfeiture to the Company of the Earnest Money deposited if any. If it is found necessary to keep the tender open for a further period, prior consent of the bidder shall be taken in writing for every further period.
- 1.3 The contractor shall submit all tender documents with signature and seal on all pages of the tender documents as a token of its acceptance and all the terms and conditions mentioned therein.

### 2. Acceptance of Tender :

- 2.1 Tenders submitted incomplete in any respect such as unattested corrections in rates, quantities, units or amounts, figures not expressed in words, totals of contract not entered etc. are liable to rejection.
- 2.2 Tenders which are not in conformity with this tender notice are liable for rejection.
- 2.3 The right to carry out the work either in conformity with or in a manner entirely different from the terms of this invitation that may be considered most suitable before or subsequent to the receipt of tenders due to exigencies, is reserved with the Company.

### 3. Quality :

The Goods shall be supplied conforming to the description/specifications/samples referred in the order/tender or agreed to upon in writing or otherwise.

### 4. Terms of payment :

Payment will be made through NEFT within 45 days of receipt and acceptance of material at our Stores, Angamaly unless otherwise specified.

### 5. Taxes, Levies & Statutory Deductions :

GST if applicable shall be mentioned separately in the quotation and will be paid extra as applicable on producing documentary evidence. Statutory deductions like TDS or as applicable will be deducted from the bills as per Rules.

### 6. Liquidated Damages:

Liquidated Damages at the rate of 1% per week subject to a maximum of 10% of the order value or as applicable in the Purchase/Work Order will be levied for deliveries beyond the mutually agreed date mentioned in the order.

7. Evaluation of the Offers shall be on the basis of "To-Door Cost at TELK, Angamaly" based on NET Cash outflow of TELK.
8. The Contractor shall not without the previous written approval of the Company sub contract in respect of any matter touching this contract and the Company shall not be bound by any such sub contract executed by the Contractor without its approval.
9. Any further information necessary can be obtained from the office on all working days during office hours.
10. For technical qualification we will be evaluating supplier's capability to supply quality material for the entire ordered quantity, past performance references and commercial terms offered.
11. In case the lowest bidder (L1) is not a registered / approved supplier of TELK, Angamaly, they will be allowed to supply the items only after evaluation by TELK authorities and enlisting as approved/registered supplier. They shall submit duly filled vendor capability report/supplier registration requisition form available in our website [www.telk.com](http://www.telk.com).
12. In case L1 is a new supplier to TELK, L2 may also be considered in order to meet urgent requirements.
13. TELK has the right to split the order quantities to various parties to meet our delivery commitments.
14. **Jurisdiction** : Any dispute arising out of this contract will be subject to the jurisdiction of courts having jurisdiction over the area in which our factory situates.





15. Transit insurance for the materials in the scope of supply shall be arranged by the supplier/contractor.

**16. Right to Accept or Reject the Tenders:**

16.1 The right to accept the tender in full or in part/parts will rest with TELK.

16.2 Tenders not accompanied with prescribed information or are incomplete in any respect, and/or not meeting prescribed conditions, shall be considered as non-responsive and are liable to be rejected.

16.3 TELK reserves the right to accept or reject any bid or a part of the bid or to annul the bidding process and reject all bids, at any time prior to award of contract without assigning any reason whatsoever and without thereby incurring any liability to the affected bidder or bidders on the grounds for the Buyer's action.

16.4 If the bidder gives wrong information in his tender, TELK reserves the right to reject such tender at any stage or to cancel the contract.

16.5 Bidder is requested to furnish all the details called for in the tender. In case any required data/information is/are not furnished in the offer, Purchaser reserves the right to assume the same for the purpose of evaluation/comparison and decide the Tender accordingly.

16.6 In case special conditions are mentioned in the tender documents, the same shall prevail over the General Terms & Conditions.

16.7 TELK reserve the right to procure the goods/execute the contract from elsewhere at your risk and cost in the event of failure to supply/execute the contract within the stipulated time.

16.8 TELK reserves the right to reject the bid of parties who have failed to meet contractual delivery/provide adequate after sales support for the products supplied against earlier orders.

**17. SPECIAL CONDITIONS OF SUB-CONTRACT:**

17.1 The materials for Electroplating shall be collected by the sub-Contractor from TELK Stores at Angamaly and returned to the Stores after completing the process at sub-contractor's cost and risk.

17.2 The rate quoted shall be exclusive of GST. GST if applicable shall be mentioned separately. Applicable GST will be paid extra on producing documentary evidence.

17.3 The rate quoted shall include all charges for transportation, labour, materials and incidental expenses if any for the complete execution of the contract.

17.4 The contractor shall compensate to the losses / damages if any caused to the conductors during the execution of the contract.

17.5 Necessary cleaning and polishing shall be carried out by the sub-contractor to make the surfaces scratch free smooth.

17.6 TELK reserves the right to enhance the quantity by 20% or reduce the order quantity and also to terminate the contract at any time without assigning any reason whatsoever.

17.7 TELK reserves the right to inspect / witness the processes and the processed material given for Electro-plating at any point of time at the premises of the Sub-Contractors.

17.8 Delivery schedule given is tentative. Separate release orders or instructions will be issued from time to time indicating the quantity and delivery dates.

17.9 TDS and all other statutory levies as applicable will be deducted from the bill of sub-contractor.

17.10 The contract shall be generally valid for a period of one year from the date of awarding the work order. Hence, rate quoted shall be valid for a period of one year from the date of work order issued.

17.11 Payment shall be made within 45 days of receipt of processed materials at TELK Stores and its acceptance. However, interest will not be paid for any delay in making the payment.

17.12 Liquidated Damages @ 1% per week subject to a maximum of 10% of the basic order value or as applicable in the work order will be levied for deliveries beyond the mutually agreed dates mentioned in the work order.



*Sant* 13/1/25  
Asst. Manager (Contracts & Materials)



SPEC. SHEET

ED 013

DISTRIBUTION: PP QA PW AS CI MS CW OD OLTC CT IPB GCB DESP

TYPE OF CHANGE		REASON FOR CHANGE			EXTENT OF PROGRESS	
<input type="checkbox"/> Material	<input type="checkbox"/> Working order	<input type="checkbox"/> Mistake in estimate	<input type="checkbox"/> Inadequate Strength	<input type="checkbox"/> Shop requirement	<input type="checkbox"/> Under Procurement	<input type="checkbox"/> Inservice
<input type="checkbox"/> Dimension	<input type="checkbox"/> Accessory change	<input type="checkbox"/> Mistake in drawing	<input type="checkbox"/> Inadequate Performance	<input type="checkbox"/> Not Applicable	<input type="checkbox"/> Not Manufactured	<input type="checkbox"/> Repair at Site
<input type="checkbox"/> Process	<input type="checkbox"/> Fastner change	<input type="checkbox"/> Mistake in connection	<input type="checkbox"/> Customer requirement	<input type="checkbox"/>	<input type="checkbox"/> Under Manufacturing	<input type="checkbox"/> Repair at Workes
<input type="checkbox"/> Pur.spec	<input type="checkbox"/> Not Applicable	<input type="checkbox"/> Mistake in construction	<input type="checkbox"/> QA Requirement	<input type="checkbox"/>	<input type="checkbox"/> Under Test	<input type="checkbox"/>

CUSTOMER: TELK    PRODUCT: 36KV 16KA CST-HA    QTY: -    JOB ORDER NO. 310346    SPEC. NO. 2    SUBJECT: TIN PLATING

THE FOLLOWING SHALL BE Procured Allotted Manufactured Tested Cancelled Added Modified

Qty.	Item No.	Shop	Drawing No.	Part No.	Part Name	Code No.	Material	Size of Raw Material(mm)		Mass (kg)		SIGN. (Initial with Designation & Date)
								Thick.	Width X Length	Row	Fin.	

Refer Spec No.1 of this job order no.

- Refer item no. 33 Centre conductor TK214201 R3 of 36KV 16 kA Bushing assembly TK213603 R3B :- Air end terminals of Centre conductor shall be tin plated instead of silver plating.

- 6 Copies of TK214201 R3 enclosed.

*Shubh*  
ppd.  
*ckg*  
*01/01/2025*  
ppd.

Recd. by *[Signature]*  
*01/01/2025*

THIRD ANGLE PROJECTION

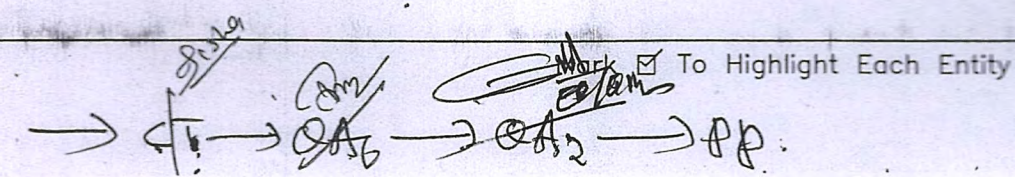



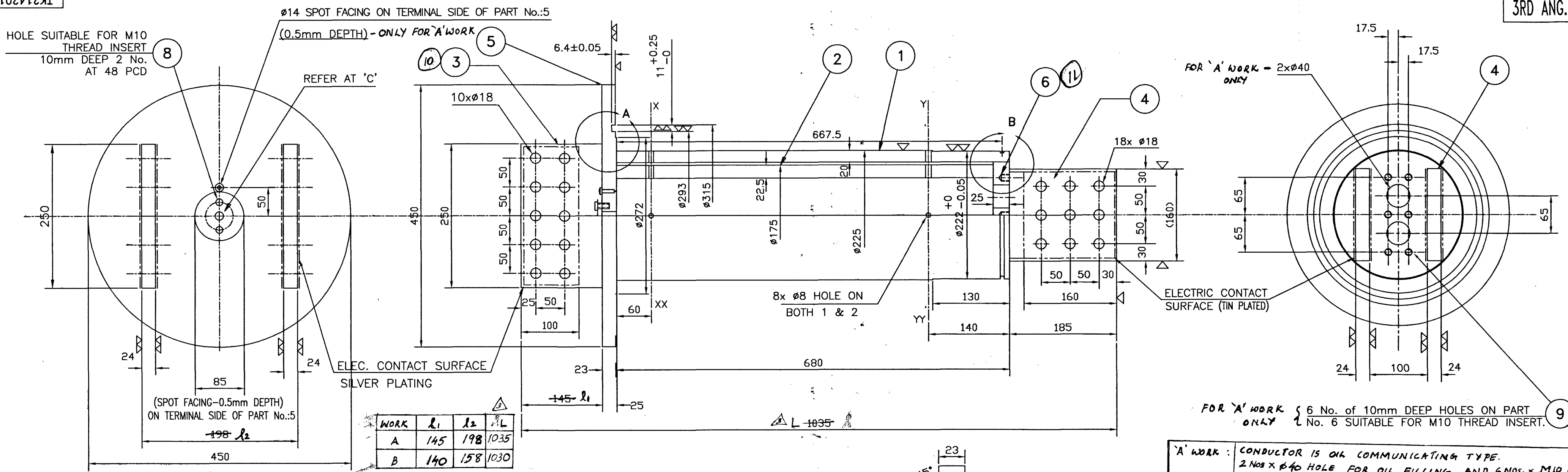

**'A' WORK :** CONDUCTOR IS OIL COMMUNICATING TYPE.  
 2 Nos x Ø40 HOLE FOR OIL FILLING AND 6 Nos. x M10 HOLES FOR FIXING BLIND COVER ARE REQUIRED FOR 'A' WORK ONLY

**'B' WORK :** CONDUCTOR IS NOT OIL COMMUNICATING TYPE.  
 BOTTOM CAP PART NO. 11 HAS NO HOLES

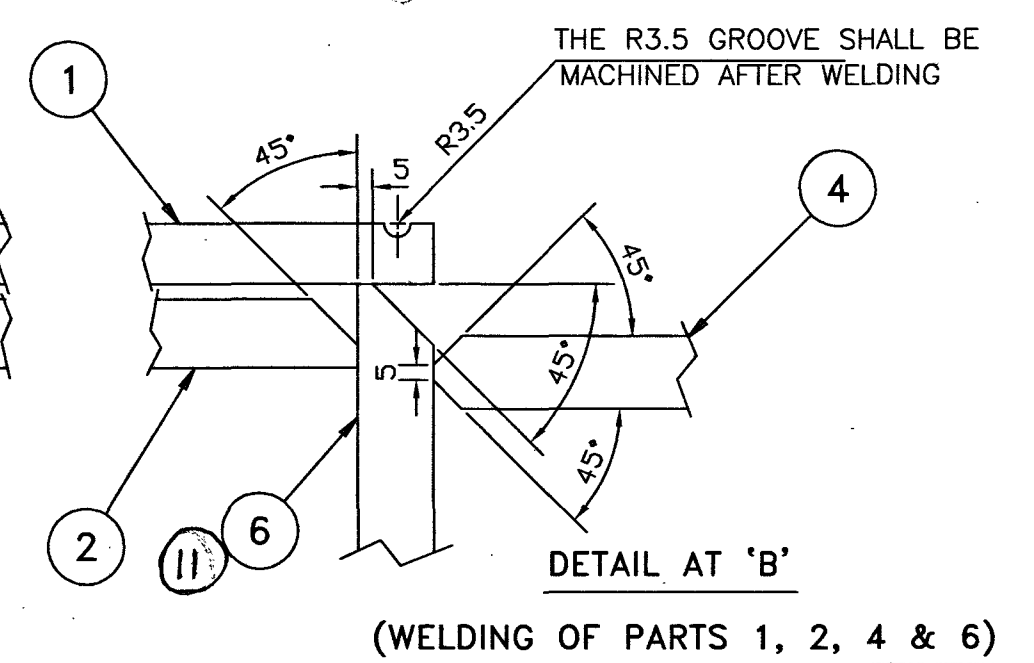
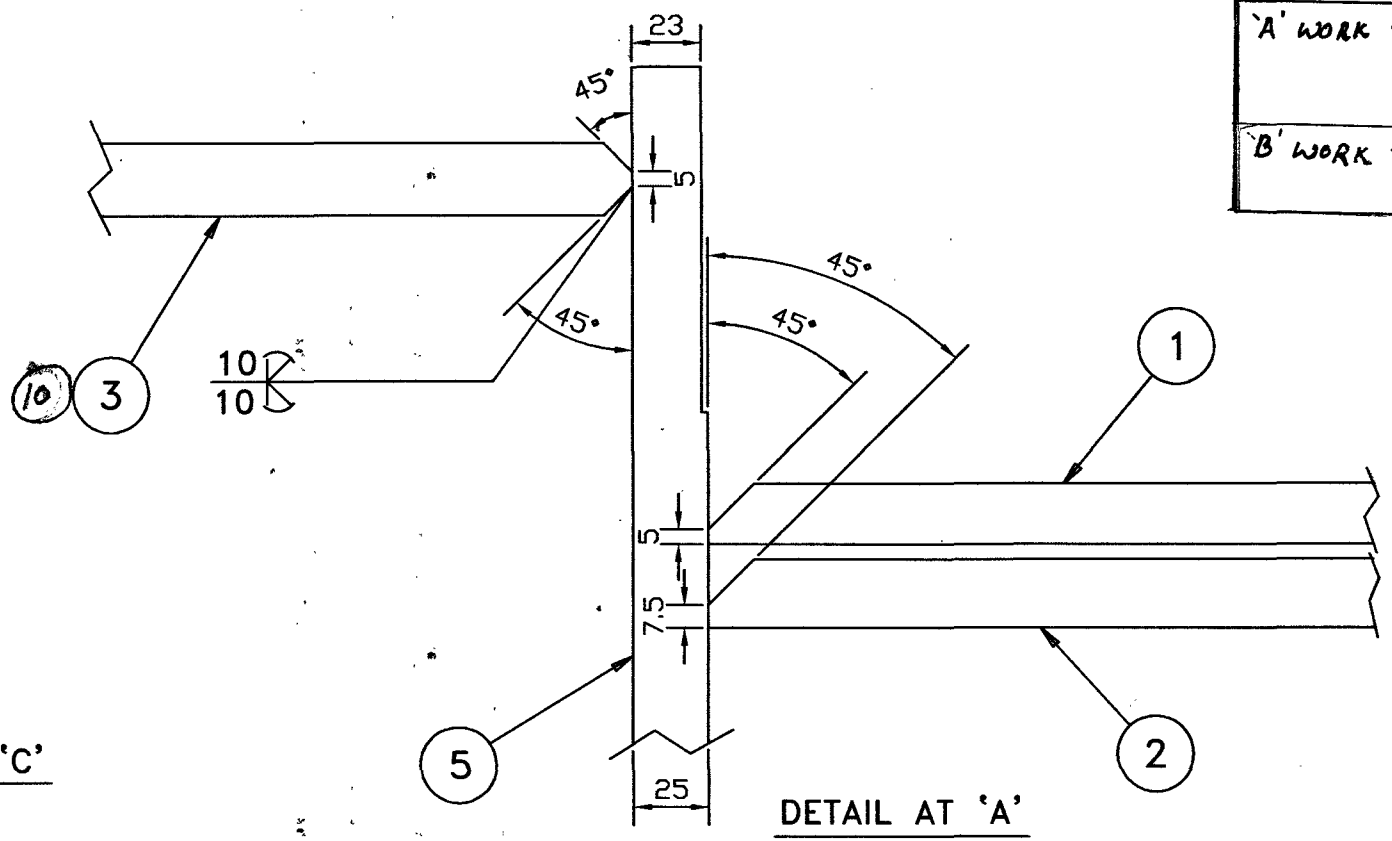
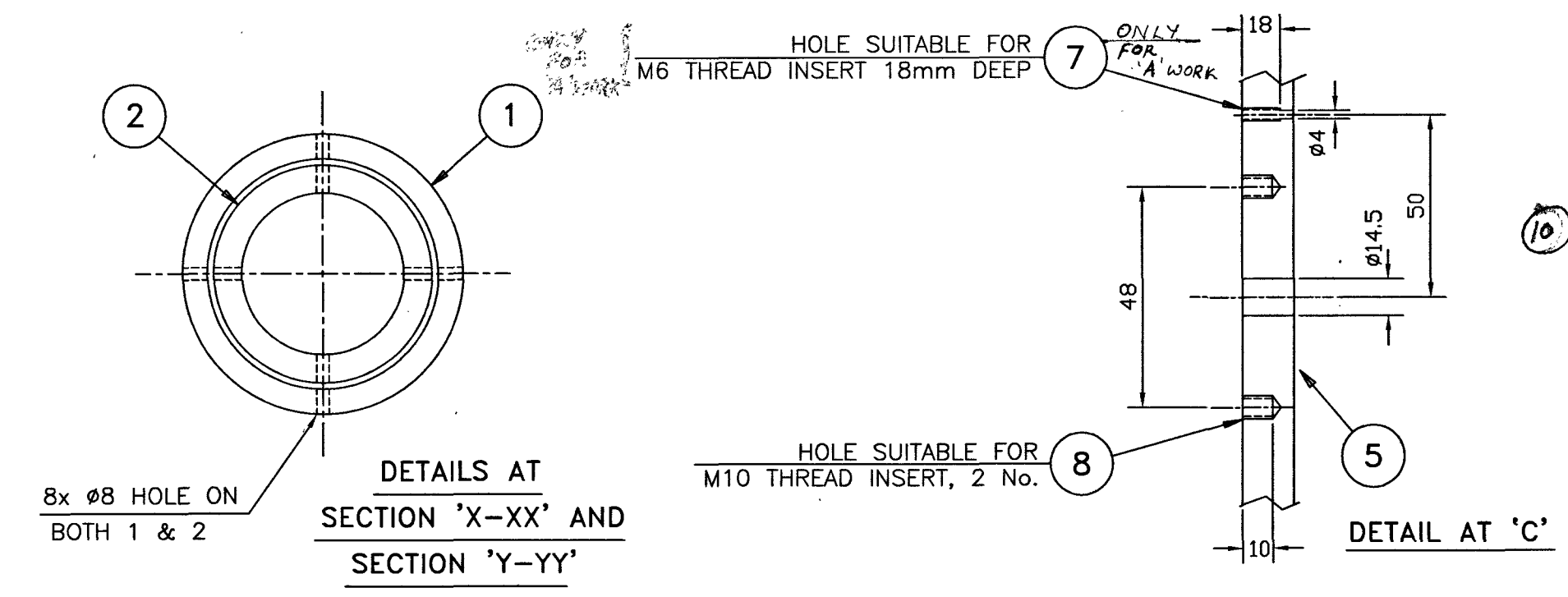

- NOTE:-**
- MATERIAL FOR PART NO.1&2 SHALL BE ALUMINIUM EXTRUSION. GRADE : 63401 WP (range2) AS PER IS:5082-1998
  - MATERIAL FOR PART 3,4&6 SHALL BE ALUMINIUM ALLOY. GRADE : 19501 AS PER IS:5082-1998
  - MATERIAL FOR PART 5 SHALL BE ALUMINIUM ALLOY. GRADE : 64430WP AS PER IS:736-1986
  - ALL WELDING SHALL BE OF METAL INERT GAS (MIG) AND PRESSURE TIGHT (PRESSURE TEST 1.5kg/cm<sup>2</sup> FOR 30 minutes)
  - ALL WELDING PROJECTIONS SHALL BE FINISHED
  - FABRICATION SHALL BE DONE AS PER WP-007 (FABRICATION PROCESS)
  - PIPE DIMENSIONS ARE NOMINAL. PART 6 SHALL BE PREPARED AFTER CHECKING INNER DIA. OF PART 1
  - MACHINING OF PART 5 SHALL BE DONE AFTER WELDING PART 3 TO ENSURE SURFACE EVENNESS
  - PART No. 3 SHALL BE ELECTRO PLATED WITH SILVER AND PART No.4 SHALL BE ELECTRO PLATED WITH TIN. (ELECTROPLATING SHALL BE DONE ONLY AFTER COMPLETING ALL WELDING WORKS)
  - APPROXIMATE FINISHED WEIGHT = 58kg - 'A' WORK ; 62.87kg FOR 'B' WORK

**TERMINAL PLATING DETAILS**

PART No. 3 SHALL BE SILVER PLATED.  
 MINIMUM PLATING THICKNESS: 10µm  
 PLATING AREA: 0.10m<sup>2</sup>

PART No. 4 SHALL BE TIN PLATED.  
 MINIMUM PLATING THICKNESS: 15µm  
 PLATING AREA: 0.1m<sup>2</sup>

**REFERENCE STANDARDS**  
 IS: 1771 - 1986  
 IS: 2450 - 1963  
 IS: 5925 - 1970

QTY	UNIT	DESCRIPTION	CODE NO.	QTY OF MAT.	SIZE OF RAW MAT.	RAW MASS (kg)	FIN. MASS (kg)
1	1	CAP	-	AL.ALLOY	25 190x190	2.44	1.82
10	10	TERMINAL	-	AL.ALLOY	25 255x145	2.51	2.11
0	0	9 SCREW THREAD INSERT	6057 00 100		M10x1.5X 10Length		
0	0	8 SCREW THREAD INSERT	6057 00 100		M10x1.5X 10Length		
0	0	7 SCREW THREAD INSERT	-		M6x1 10Length		
1	1	6 CAP	-	AL.ALLOY	25 190x190	2.44	1.65
1	1	5 CAP	-	AL.ALLOY	25 455x455	13.97	10.73
2	2	4 TERMINAL	-	AL.ALLOY	25 160x190	2.05	1.75
2	2	3 TERMINAL	-	AL.ALLOY	25 255x150	2.6	2.35
1	1	2 CENTRE CONDUCTOR	-	AL.ALLOY	22.5 175 ODx665	19.4	19.1
1	1	1 CENTRE CONDUCTOR	-	AL.ALLOY	20 225 ODx690	24.0	23.5

NO.	BRIEF RECORD OF CORRECTION	REVISED	CHECKED	APPROVED	DATE	NO.	BRIEF RECORD OF CORRECTION	REVISED	CHECKED	APPROVED	DATE
3	DIMENSION OF TOTAL LENGTH CORRECTED				17.10.15						
2	'B' WORK ADDED.				16.07.15						
1	Estimation of part no 5 corrected				22.12.2014						

**CONDUCTOR**  
 (36KV 16KA BUSHING)

TELK DRG NO R/12/3

**TK214201**